

APPLICATION

Power pack is intended to supply hydraulic system with hydraulic fluid (oil) according to the required parameters (pressure and displacement).

DESCRIPTION

Power pack in standard consists of the oil tank and the key accessories such as:

- filler breather filter;
- oil level indicator (optical) with possibility of electric indication on minimum level;
- thermometer;
- revision seals;
- oil drain plug;
- magnetic filter (or plug)

and of pumping unit (electric motor - vane pump), oil filter (low pressure filter), and also measuring block with pressure gauge switch, pressure gauge and output connections.

Standard version of the power pack can be extended (upon customer request) with:

- hydraulic control system – according to individual scheme;
- temperature regulation system (air cooler or water cooler, heater, heat sensor, temperature regulator);
- other equipment and hydraulic machines, which are not included in the data card, after prior consultation with the manufacturer
- electric control system

The extension of hydraulic system can be made:

- on the blocks for column mounting (**WK560 520**) – standard version,
- on multi-station manifold blocks type **ULRA 6...** (**WK 450 499** or **ULRA 10...** (**WK 450 500**))
- in board.system (using individual subplates type **G...**).

TECHNICAL DATA (table1)

Nominal oil tank capacity	100 dm ³	
Oil capacity difference corresponding to oil level difference max. - min	up to 21,8 dm ³	
Hydraulic fluid	mineral oil	
Operating temperature range	- 10 up to + 70 °C	
Standard filtration	16µm	
Motor supply voltage	230/400V 50Hz (other, if agreed)	
Type of pump	V3/25	02PSP - 1- 20
Operating pressure	up to 16 MPa	up to 16 MPa
Viscosity	16 ÷ 160 mm ² /s	16 ÷ 160 mm ² /s
Displacement [at 1450 revolutions/min; p = 1MPa]	27,5 dm ³ /min	27 dm ³ /min
Additional information on the pump according to the data card	WK 409 073	WK 577 236

HYDRAULIC SCHEME

Connections (table 2)

Port		P	T	A	B
Connections	for NS6	G1/2"	G1/2"	G1/2"	G1/2"
	for NS10	G1"	G1"	G3/4"	G3/4"

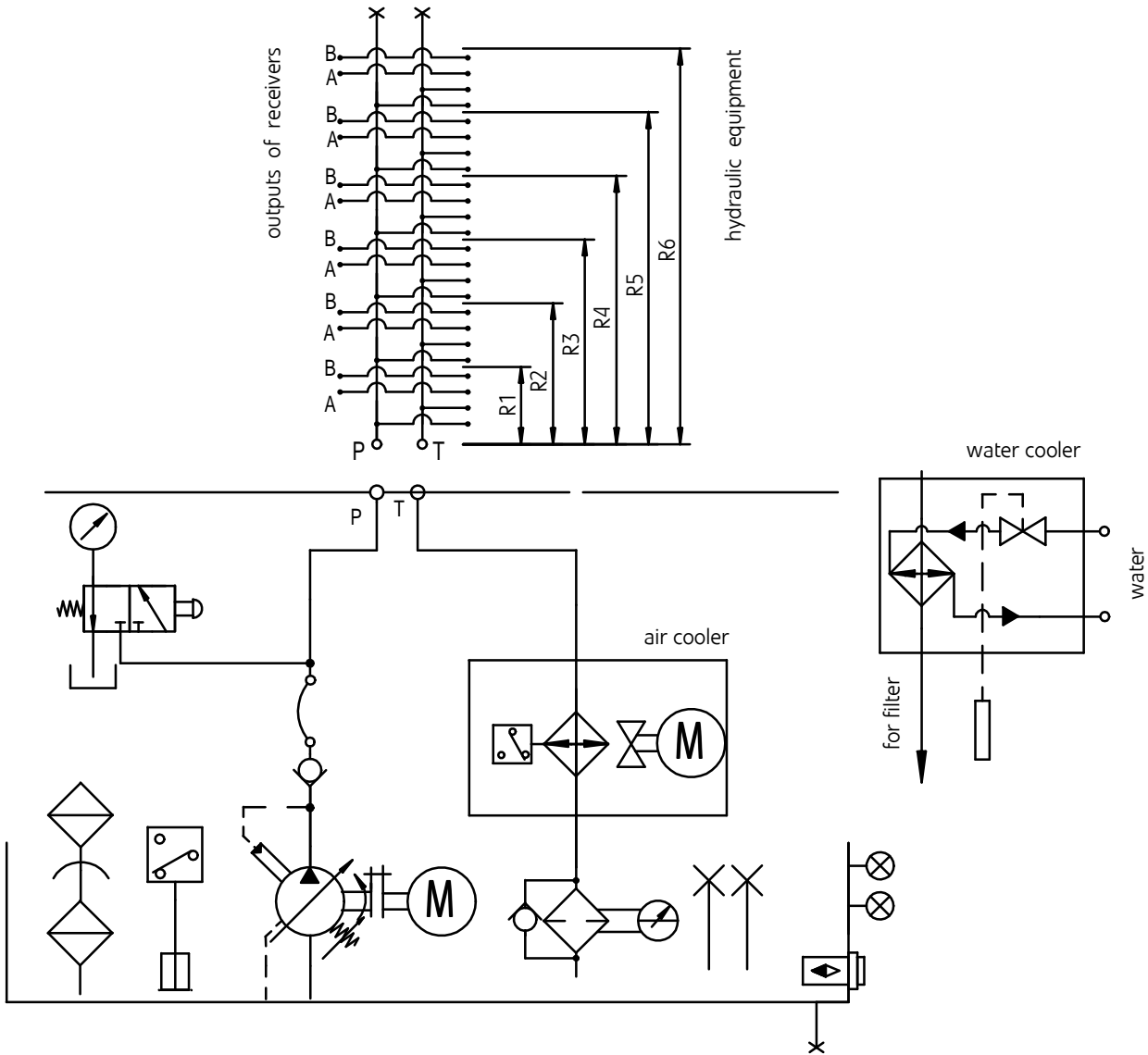

Operating pressure range depending on the motor power and type of pump (table 3)

Motor type	Power [kW]	02PSP - 1- 20	V3/25
		pressure [MPa]	pressure [MPa]
SKg 90 L4	1,5	-	2,5
SKg 100 L4A	2,2	-	4,0
SKg 100 L4B	3	5,0	6,3
SKg 112 M4	4	6,5	7,5
SKg 132 S4	5,5	9,0	10
SKg 132 M4	7,5	12,5	-
SKg 132 M4PC	11	16	-

OVERALL AND CONNECTION DIMENSIONS

Dimensions in brackets referred to NS6

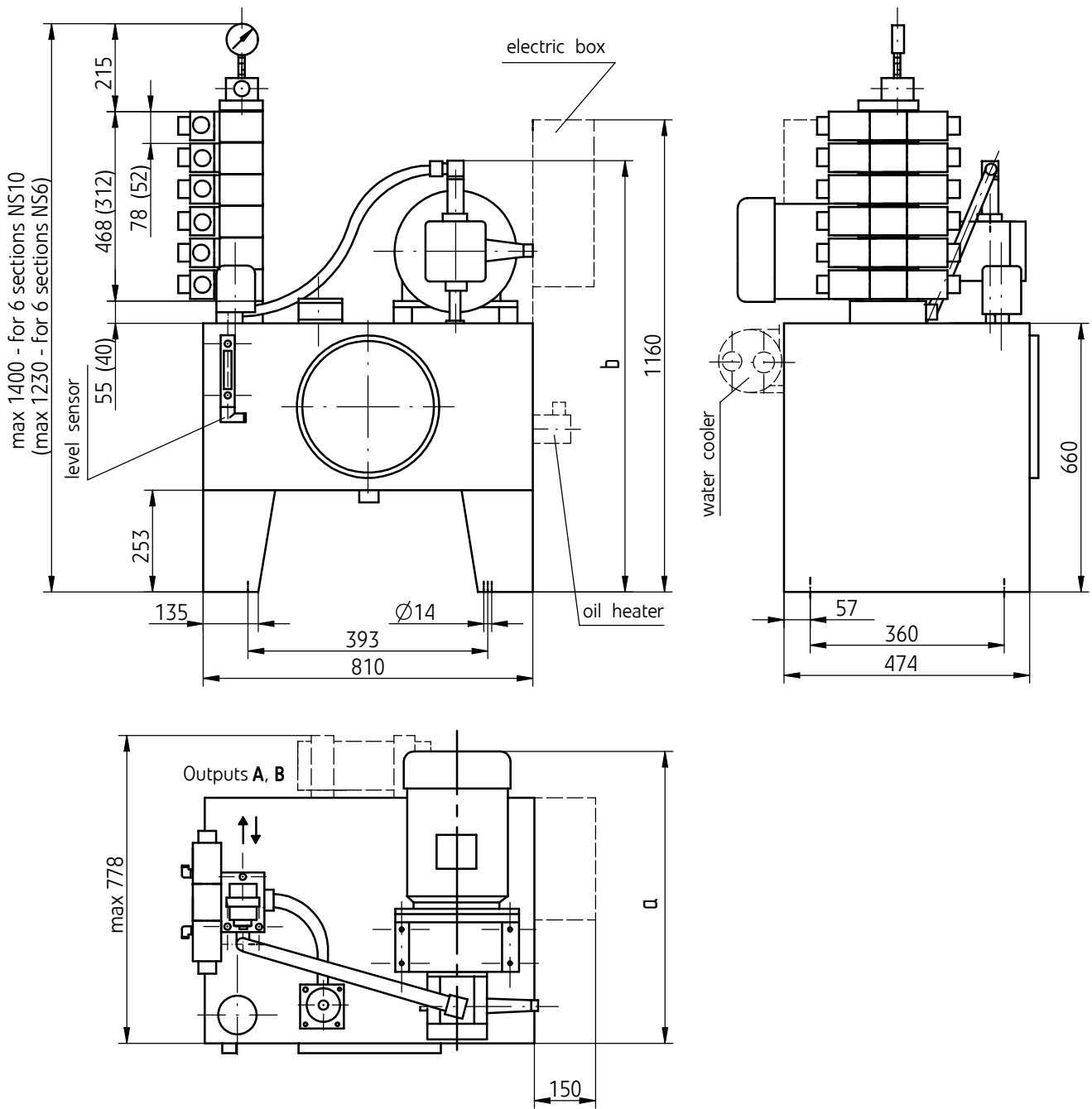

Overall dimensions depending on the motor power and type of pump (table 4)

Motor type	Dimension	02PSP-1-20	V3/25
SKg 90 L4 1,5 [kW]	a	-	530
	b	-	1030
SKg 100 L4A 2,2 [kW] SKg 100 L4B 3 [kW]	a	615	570
	b	1065	1040
SKg 112 M4 4 [kW]	a	625	575
	b	1080	1052
SKg 132 S4 5,5 [kW] SKg 132 M4 7,5 [kW] SKg 132 M4PC 11 [kW]	a	725	680
	b	1100	1072

ADDITIONAL

When selecting power pack to the machine it is necessary to consider its total heat balance by specifying oil temperature in the tank – it should not exceed 55°C (328 K).

If necessary, oil cooler must be used for the hydraulic system. Thermal power output of the power pack tank to the environment can be estimated using below formula or diagram.

$$N_{\text{output}} = k \times A \times \Delta T$$

- N_{output} [W] - thermal power output of the tank
 A [m²] - active surface area of the tank for the power pack tank UHJV 100 $A = 1,4 \text{ m}^2$
 k [W/m² x K] - heat exchange factor
- $k = 5 \text{ W/m}^2 \times \text{K}$ - when poor air circulation, unfavourable location,
 - $k = 10 \text{ W/m}^2 \times \text{K}$ - normal air circulation from all directions,
 - $k = 20 \text{ W/m}^2 \times \text{K}$ - when intensive air circulation (unnaturally forced),
- ΔT [K] - temperature difference between the tank (oil) and the environment

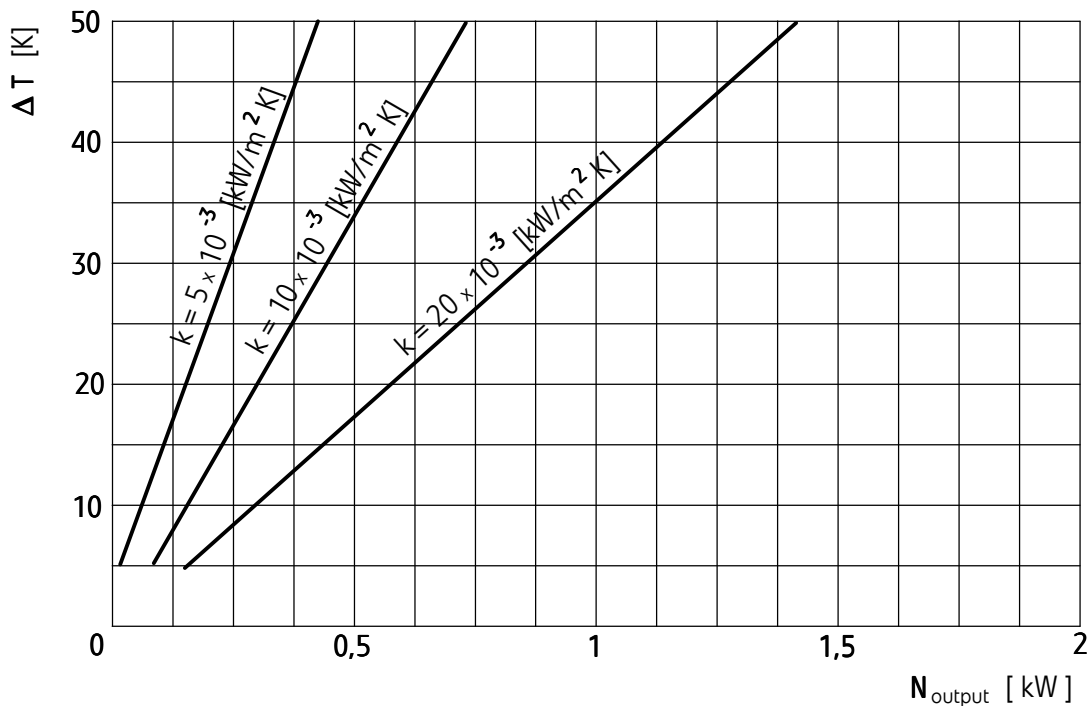

Thermal power output of the power pack tank UHJV100

HOW TO ORDER

Any order should be addressed to the manufacturer according to the below coding.

UHJV	100	+	+	+	+	+	+	+	+	★
-------------	------------	---	---	---	---	---	---	---	---	---

Tank capacity

100 dm³ = 100

Type of pump

02PSP -1-20 = 20
V3/25 = 25

Motor power (according to the table 3)

1,5 kW = 1,5
2,2 kW = 2,2
3,0 kW = 3,0
4,0 kW = 4,0
5,5 kW = 5,5
7,5 kW = 7,5
11,0 kW = 11,0

Nominal size of hydraulic elements mounted

(referred to connections of directional valves)

NS6 = 6
NS10 = 10

Designed version

- standard version (without connection for directional valve) = no designation
- with the connection for one directional valve = R1
- with the connection for two directional valves (parallel connection of apparatus) = R2
- with the connection for three directional valves (parallel connection of apparatus) = R3
- with the connection for four directional valves (parallel connection of apparatus) = R4
- with the connection for five directional valves (parallel connection of apparatus) = R5
- with the connection for six directional valves (parallel connection of apparatus) = R6

Oil level indicator

without oil level indicator = no designation
with oil level indicator of minimum level (electric) = N1

Cooler

without cooler = no designation
air cooler (according to the table 5) = P1 or P2
water cooler (according to the table 6) = W1 or W2

Successive number of power pack version

(given by the manufacturer of the power pack when order confirmed) = XXXX

Further requirements in clear text

(to be agreed with the manufacturer)

Coding example: UHJV 100 - 25 - 3,0 -10 - R4 - N1- P1- XXXX

NOTE:

Type, quantity and placing hydraulic equipment (directional valves, valves and other), must be specified in the hydraulic scheme or in another clear way.

BASIC TECHNICAL PARAMETERS OF THE ACCESSORIES

Air cooler (table 5)

Type	Designation	Motor power	Voltage	Rate of revolution	Power output for $\Delta t = 20\text{ }^{\circ}\text{C}$
MG AIR 2015K	P1	0,045 kW	230/400V 50Hz	~ 2850 revolutions/min	up to 2,5 kW
MG AIR 2024K	P2	0,12 kW	230/400V 50Hz	~ 2670 revolutions/min	up to 4,5 kW

Water cooler (table 6)

Type	Designation	Connection thread for water	Thermostat type	Power output for $\Delta t = 35\text{ }^{\circ}\text{C}$
MGE 80-120-1	W1	G1/2	AVTA 15	3 ÷ 7 kW
MGE 80-150	W2	G1/2	AVTA 15	4 ÷ 8 kW

Oil level indicator with electric indicator (table 7)

Type	Supply voltage	Current	Contact load capacity	Contact state
SNK 127V/O/O/12R	50V AC/DC	0,2A	2,5 W	Open at minimum

Below hydraulic equipment manufactured by "PONAR-WADOWICE" S.A. that can be used for control systems (table 8)

Directional spool valve, electrically operated	WE 6	according to WK 499 502
Directional spool valve, hydraulically operated	WH 6	according to WK 420 170
Directional spool valve, hand lever operated	WMM 6	according to WK 420 170
Directional spool valve, rotary knob operated	WMD 6	according to WK 420 170
Pressure reducing valves, sandwich plate	UZRC 6	according to WK 493 061
Pressure sequence valves, sandwich plate	UZKC 6	according to WK 393 060
Check valves, sandwich plate	WZZC 6	according to WK 450 355
Double check valves, pilot operated	Z2S 6	according to WK 450 360
Double check valves, sandwich plate	Z2FS 6	according to WK 450 232
Pressure switches (with subplate UŁBC 6)	USPH 4	according to WK 450 398
Pressure relief valves	UZPR 6	according to WK 494 060

Directional spool valve, electrically operated	WE 10	according to WK 499 495
Directional spool valve, hydraulically operated	WH 10	according to WK 420 180
Directional spool valve, hand lever operated	WMM 10	according to WK 420 180
Directional spool valve, rotary knob operated	WMD 10	according to WK 420 180
Pressure reducing valves, sandwich plate	UZRC 10	according to WK 494 721
Pressure sequence valves, sandwich plate	UZKC 10	according to WK 493 720
Check valves, sandwich plate	WZZC 10	according to WK 450 367
Double check valves, pilot operated	Z2S 10	according to WK 450 309
Double check valves, sandwich plate	Z2FS 10	according to WK 450 233
Pressure switches (with subplate UŁBC 10)	USPH 4	according to WK 450 398

PONAR Silesia S.A.
ul. Wojska Polskiego 29
34-100 Wadowice
tel. +48 33 823 44 41 - 45
fax. +48 33 823 39 36
www.ponar-silesia.pl

